

■ Transducer bridge circuit and connector alignment

Bridge circuit inside and wiring system are given as follows, but not applicable to some products. When connector plug is required, specify it on order to install the plug to the transducer cable.

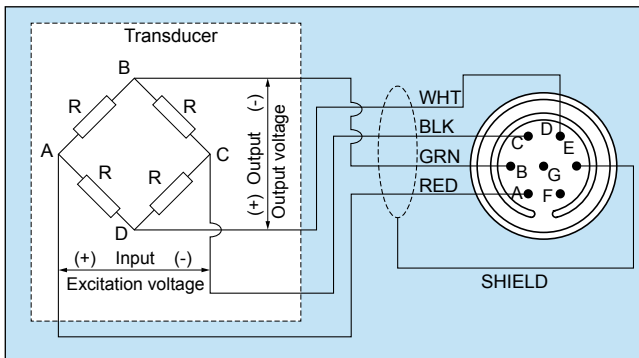

■ Transducer Input/Output resistance

Input/Output resistance (Ω)	Pin alignment of connector and resistance between cables (Ω)					
	A-C RED-BLK	B-D GRN-WHT	A-B RED-GRN	A-D RED-WHT	B-C GRN-BLK	C-D BLK-WHT
120	120	120	90	90	90	90
350	350	350	263	263	263	263

■ Measurements with constant voltage method and constant current methods

Constant voltage method

In this method, the bridge excitation voltage (voltage applied between A and C terminals of the strain measuring instrument) is kept constant. Our instruments commonly use this method, and our transducers are usually calibrated using this method. When the transducer cable is extended, sensitivity (calibration coefficient) of the transducer needs correction.

Constant current method

In this method, the bridge excitation current (current flows between A and C terminals of the strain measuring instrument) is kept constant. This method has the advantage that the output of the transducer does not decrease even if the transducer cable is extended. However, the input/output resistance of the transducer must be a specified value (usually, 120 or 350 ohm). It must also be noted that the sensitivity (calibration coefficient) of the transducer may differ for constant voltage method and constant current method.

■ Rated output and strain value

The output (rated output) of a transducer is expressed as mV/V. It is the output voltage when a maximum load is applied to the transducer. It shows the output voltage generated when 1V is applied.

Example:

1.5mV/V means that 1.5mV is output when a load of the transducer's full capacity is applied while 1V is applied as bridge excitation. If 2V is applied (bridge excitation of a strain measuring instrument):

$$1.5\text{mV/V} \times 2\text{V} = 3\text{mV}$$

Therefore, if the gauge factor is set at 2.00 (coefficient set at 1.000) the output voltage of the transducer is 3mV and the value to be shown on a strain measuring instrument can be calculated by the following expression, which is formulated based on the voltage-to-strain relational expression:

$$\Delta e = E/4 \times K \times \epsilon$$

$$\epsilon = 4\Delta e/KE$$

where, Δe : Output voltage (V) of a transducer

E : Excitation voltage (V)

K : Gauge factor of a strain measuring instrument

ϵ : Reading on a strain measuring instrument

With K, E and Δe defined as 2.00, 2V, and 3mV, respectively, 3mV is equal to 0.003V and therefore,

$$\epsilon = 0.003 = 3000 \times 10^{-6} \text{ strain}$$

By setting the gauge factor of a strain instrument at 2.00 and expressing the output voltage of a transducer at 1V excitation, we have the following:

$$2\Delta e = \epsilon, \text{ then}$$

$$1\text{mV/V} = 2000 \times 10^{-6} \text{ strain}$$

$$2\text{mV/V} = 4000 \times 10^{-6} \text{ strain}$$

■ Decreased sensitivity due to a long cable used to connect to a transducer

When a measuring instrument with constant voltage method is used and the transducer cable is extended from the original cable used for the calibration (shown in the test data), the output of the transducer is decreased. The output (calibration coefficient) will be as in the following formula. Correction should be made using this formula when necessary.

$$\epsilon_s = \epsilon_m \times \frac{R}{R+r \times L}$$

ϵ_s : Corrected output (calibration coefficient)

ϵ_m : Original output (calibration coefficient) given on the test data

R : Input resistance (Ω) of the transducer

r : Total resistance of the input side of the extended cable per meter (Ω/m)

L : Length of the longer cable (m)

■ Resistance per meter of a cable used to connect to a transducer

Cross section area (sq. mm)	Total resistance per meter (Ω)
0.005	7.2
0.05	0.63
0.08	0.44
0.09	0.40
0.14	0.25
0.3	0.12
0.35	0.11
0.5	0.07
0.75	0.048

■ TEDS support

TEDS is an abbreviation of Transducer Electronic Data Sheet. A TEDS compatible transducer has sensor information conforming to IEEE1451.4 as electronic data inside. It enables automatic input of sensor information including the sensitivity and serial number into the measuring instrument. This automation eliminates wrong settings, significantly reduces the time required for settings and realizes efficient and simple works.

For more details of TEDS compatible transducers and measuring instruments, please contact us.